

Post and Rail Fencing (1.2m)

1. Wood - All timbers to receive 2no coats of Dulux weathershield stain, colour to be confirmed. First coat of stain to be applied prior to erection.
- Fence orientation and distance from boundaries to be agreed on site.
- All saw timber to be tanalised
2. Posts - 125 x 75mm timber posts at 1800mm centres
3. Rails - 3no 100 x 38mm thick sawn softwood horizontal rails bolted to posts.

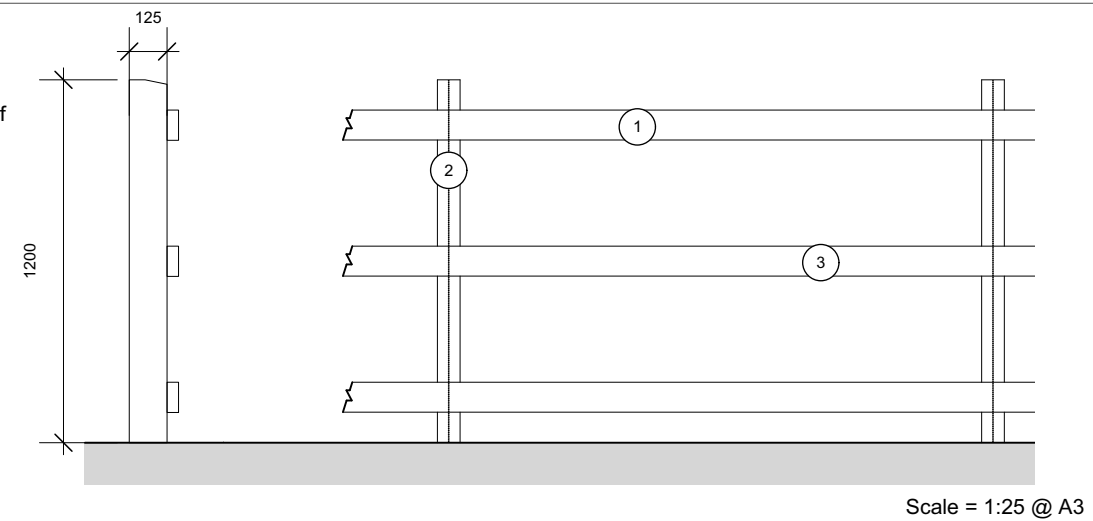

Palisade Fencing (2.4m)

1. Steelway-Fensecure Korapal Palisade general purpose fencing
- Pales to have Acute type heads
- Painted dark grey finish
2. 40 x 40 x 6mm R.S.A. galv. top & bottom rails

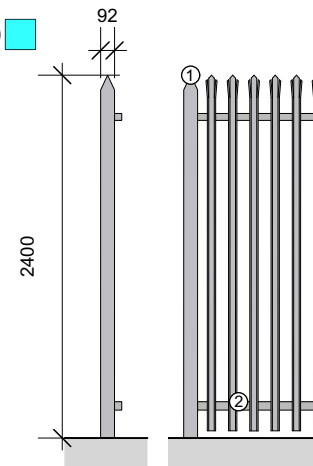

Paladin Fencing (with Timber inserts) (2.4m)

- Jacksons Euroguard paladin fencing or similar
- Black PPC coating to all components
 - 5mm wire mesh
 - Concrete footings to SE detail
 - Fence posts - 60 x 40 x 2 RHS

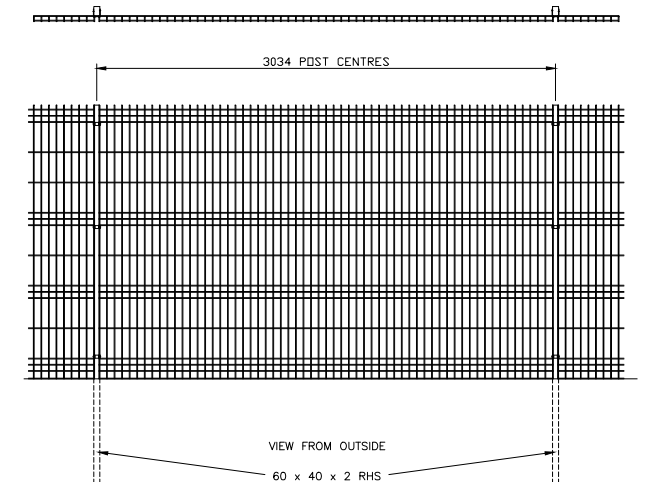

Timber Knee Rail

1. Knee rail supplied and installed by landscape contractor
2. 100x100mm top rail (preservative treated, s/wd. sawn finish).
3. 100x100mm posts (as above) 1.5m maximum spacing, ends shaped to receive top rail. Buried ends to be creosote impregnated as specified.
4. Concrete foundation to post
5. 100mm wide zinc strap. 37mm galvanised clout nail fixing.
6. Timber stain to match site timber work.

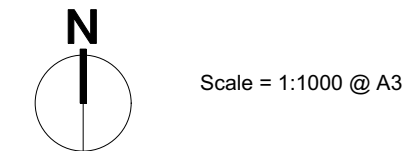
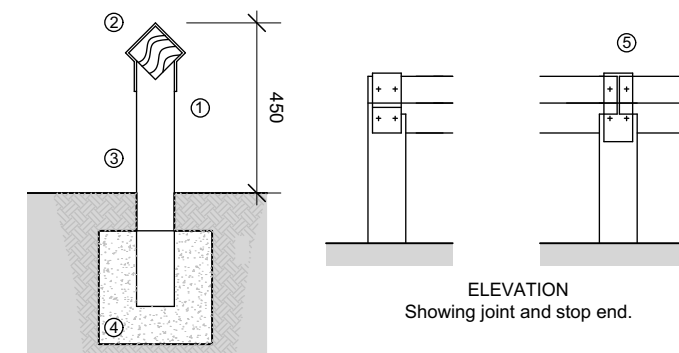

Scale = 1:1000 @ A3

Close Boarded Fence (1.8m)

1. Wood
- Finish to match nearby and existing post and rail fence.
- All sawn timber to be tanalised.
2. Posts - 100 x 100mm timber posts at 2000mm centres.
3. Fence Boarding - 100mm x 15mm thick sawn softwood boarding with 15mm overlap.
4. Rails - 3 no 75 x 75mm thick sawn softwood horizontal rails bolted to posts.
5. Gravel Board - 130 X 25mm thick sawn softwood board.

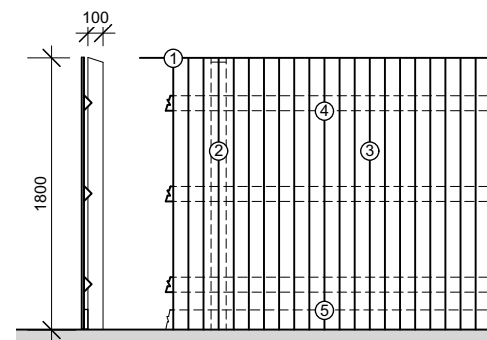

Chain Link Fence (As Existing)



Chartered Architects
Chartered Building Surveyors
Interior Designers
CDM Services

Glentworth Court, Lime Kiln Close
Stoke Gifford, Bristol BS34 8SR
+44 (0)117 931 2062
www.kendallkingscott.co.uk

Project
Aldi Lampeter, Pontfaen Road

Client
Aldi Stores Ltd

Scale Paper Size Filename
Various ISO A3 190866 CONDITIONS Boundaries.vwx

P2 05/11/2021 DM JS Site plan updated
P1 19/10/21 JKCJS Drawing Issue
Rev Date By Ap Note

Drawing Title
Proposed Boundary Treatment Plan

Project Number Drawing Number Revision
190866-1903 P2

Date Drawn Checked Purpose/Status
19/10/2021 JKC JS PLANNING

Only to be used on the site for which designed. The electronic transmission of designs/information contained in this drawing is carried out entirely at the User's risk and Kendall Kingscott Ltd. will have no liability for any errors or inaccuracies arising therefrom. The production of amended or updated information from the said designs/information by the User is entirely the responsibility of the User and Kendall Kingscott Ltd. shall have no responsibility in respect thereof whatsoever.